

INSTALLATION PROCEDURE, MIDSIZE AND TALL TOPS WITHOUT BULKHEAD

Vehicle prep

Notice where the top will interface with the vehicle. The bulb seal on the front of the hard top will rest on the windshield frame. The doorposts will fit over the vehicle B-pillars. The four L-brackets inside the top will rest on the vehicle wheel wells. The sides and rear of the hard top will fit over the outside perimeter of the vehicle. The gasket on the bottom of the hard top will rest on the wheel wells. The following steps outline removal of items that typically interfere with top installation. Not all vehicles are equipped the same so some of these steps may not apply to your vehicle. Additional items may also need to be removed for proper installation.

1. Remove the canvas and mounting hardware
2. Remove the two canvas twist fasteners from the windshield frame. Remove any burrs.
3. Remove the self-tapping screws that attach the slide rail to the windshield.
4. Pry the slide rail loose. Scrape the seal off of the windshield frame.
5. Fill the screw holes with silicon.
6. Remove the two rubber grommets from the roadside and curbside corner posts of the windshield.
7. Remove the canvas top tie downs from the top of the wheel wells.
8. Remove 4 bolts from top (near the rear) of wheel wells.

Installation

All of the hardware provided for mounting the top is stainless steel. **NEVER-SEIZE SHOULD BE USED TO PREVENT THE HARDWARE FROM GALLING.**

1. There are two rear L- brackets attached to the top with three bolts each (they are located in inside the top on either side of the rear door). Loosen the nuts so that the rear L-brackets can slide up and down.
2. There are two mid L-brackets attached to the top with two bolts each (they are located inside the top just behind the rear door cutouts, one on each side). Loosen the nuts so that the mid L-brackets can slide up and down.
3. When the top is installed it is important to have the gasket which seals the top to the windshield frame pulled forward. This can be accomplished by placing cardboard on the windshield frame before lowering the top onto the vehicle and pulling the cardboard forward

once the top is in place.

4. The hard top rear doors are equipped with lift-off hinges. They should be removed prior to placing the top onto the vehicle.

5. Carefully lower the top onto the vehicle. The doorposts (located between the door cutouts) should be aligned with the vehicle B-pillars as the top is lowered as this will set for-aft position of the top.

6. Position the top all the way forward. If cardboard was used on the windshield frame remove it now by pulling forward. Insure that the rear of the hard top is fully seated and that the gasket between the top and the wheel wells is being compressed. Install and adjust the vehicle doors. If necessary the top can be moved slightly rearward to accommodate the doors.

7. Open the vehicle tailgate and reinstall the hard top rear doors. When the hard top rear doors are closed the gap between them should be even top to bottom. The gap between the top of the doors and the frame should also be even. The sides of the top can be move inboard or outboard until even gaps are achieved. The sides of the top can be moved outboard with a pry-bar on the rear L-brackets. The provided strap can be used to move the sides of the hard top inboard by attaching it to the D-rings on the rear of the hard top. Do not over-tighten the strap as this could result in damage to the top. When even gaps are achieved tap the rear L-brackets down until they contact the wheel well. See fig 1-1.

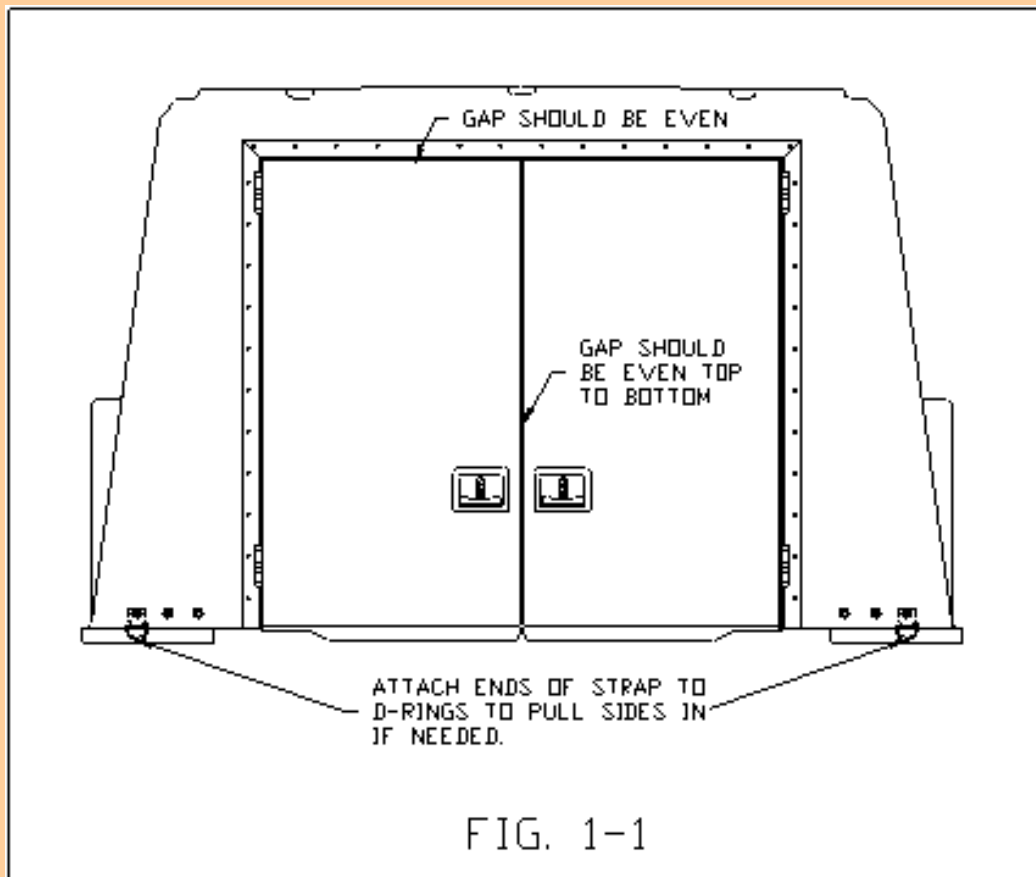

8. With a 3/8" drill bit, drill through L-bracket slots and the vehicle wheel wells. When possible drill through the center of the slots. If the top is equipped with side storage compartments an angle drill will be needed. If an angle drill is not available mark the location of the rear L-bracket

slots, remove the top, and drill the four mounting holes with a 3/8" drill bit. Repeat steps 4, 5, 6, and 7. Fasten the rear L-brackets to the vehicle with (4 ea.) 3/8"-16 x 1-1/2" hex bolts, (4 ea.) 3/8"-16 nyloc nuts, (4 ea.) 3/8" flat and (4 ea.) 3/8" fender washers. Tighten the bolts that secure the rear L-brackets to the top. See figure 1-2.

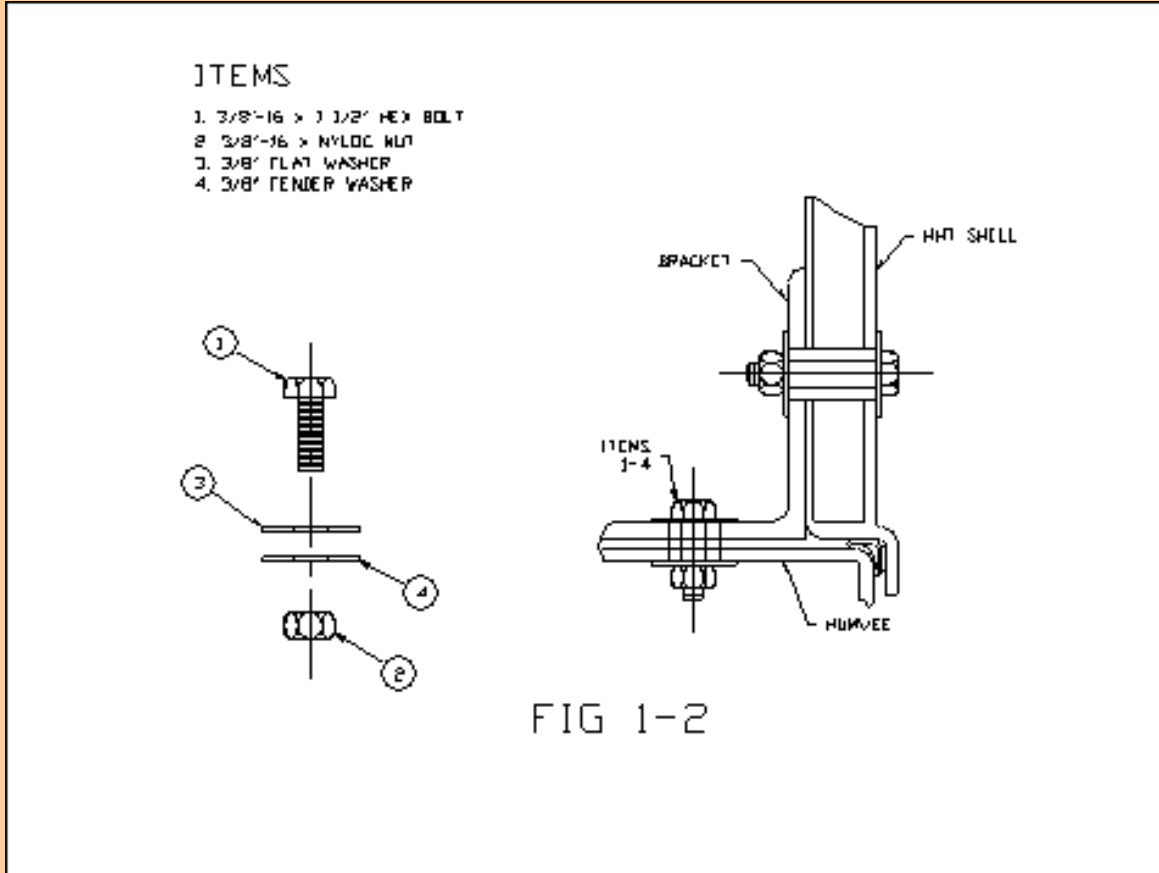

9. Remove the D-rings from the rear of the hard top. Reinstall the bolts and washers (discard the original nuts) with (2 ea.) 3/8"-16 nyloc nuts. Tighten the six bolts that secure the rear L-brackets to the top.

10. Position the strikes on the windshield frame and mark the holes. Drill the holes in the windshield frame with a 1/4" drill bit. Install the strikes with (4 ea.) rivets. See figure 1-3.

ITEMS

- 1 LATCH
- 2 STRIKE
- 3 RIVETS
- 4 1/4" x 1 1/4" PAN HEAD WOOD SCREW
- 5 1/4" WASHER
- 6 #10 WASHER HEAD SCREW

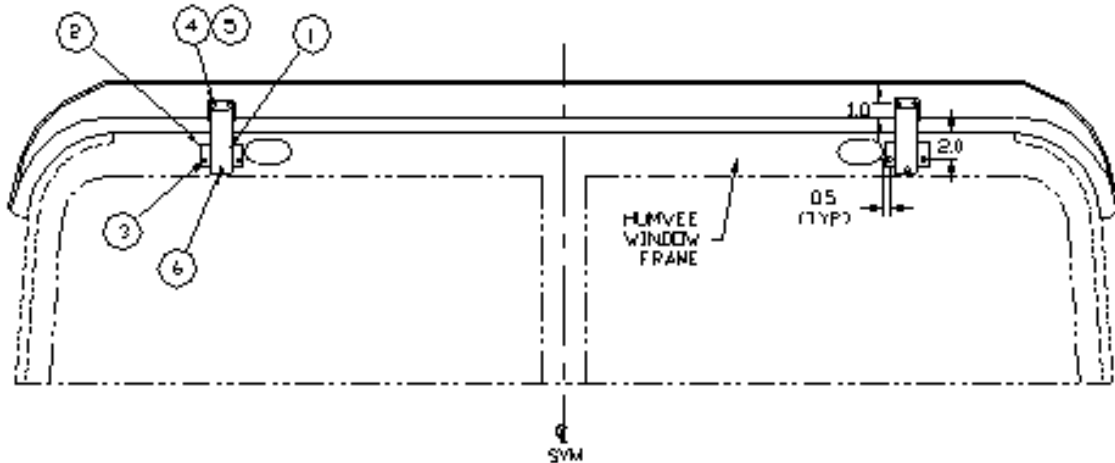

FIG. 1-3

11. Install the latches into the strikes and close the latch. Adjust length of the latches so that the center of the latch mounting holes is above the bottom of the rib by 1". Mark the holes for the latches on the reinforcement rib. Remove the latches from the strikes. Drill the holes with a 3/16" drill bit a maximum of 1-1/4" deep. **NOTE: DRILLING DEEPER THAN 1-1/4" WILL DAMAGE THE TOP.** Install the latches with (4 ea.) 1/4" x 1-1/4" pan head wood screws and (4 ea.) 1/4" washers. Adjust the latches so that the top is pulled tightly to the windshield frame and secure the latches. The latch handles have a small hole near the bottom. Drill through these holes into the windshield frame with a 1/8" drill bit. Secure the handles to the windshield frame with (2 ea.) #10 washer head screws. See figure 1-3.

12. With a 1/4" drill bit, drill through the two holes one each door post and roll bar. Fasten the doorposts to the B-pillars with the (4 ea.) 1/4"-20 x 2 hex bolts, (4 ea.) 1/4"-20 nyloc nuts, (4 ea.) 1/4" flat and (4 ea.) 1/4" fender washers provided. See figure 1-4.

ITEMS

- 1 1/4"-20 x 2' HEX BOLT
- 2 1/4"-20 NYLOC NUT
- 3 1/4" FLAT WASHER
- 4 1/4" FENDER WASHER

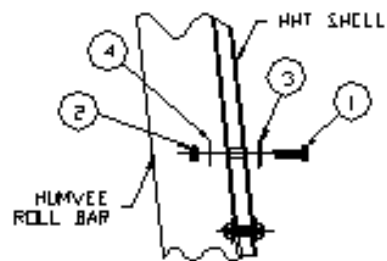
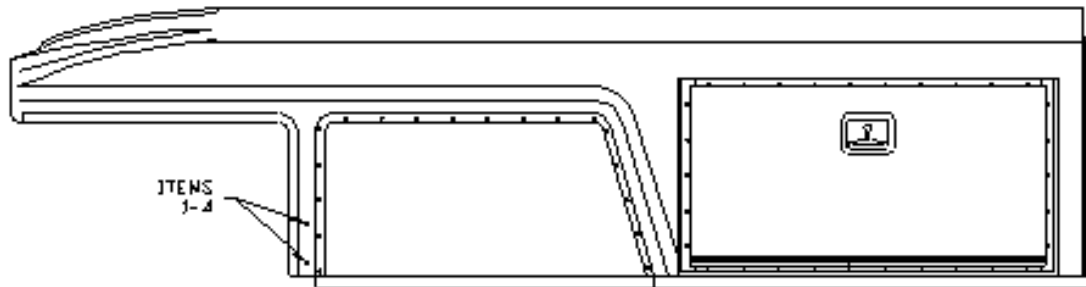

FIG 1-4

13. Tap the mid L-brackets down until they contact the wheel well. With a 3/8" drill bit, drill through the mounting holes on each bracket. Fasten the mid L-brackets to the vehicle with (2 ea.) 3/8"-16 x 1-1/2 hex bolts, (2 ea.) 3/8"-16 nyloc nuts, (2 ea.) 3/8" flat and (2 ea.) 3/8" fender washers. Tighten the bolts which secure the mid L-brackets to the top. See figure 1-5.

ITEMS

1. 3/8"-16 x 1 1/4" HEX BOLT
2. 3/8"-16 NYLOC NUT
3. 3/8" FLAT WASHER
4. 3/8" FENDER WASHER

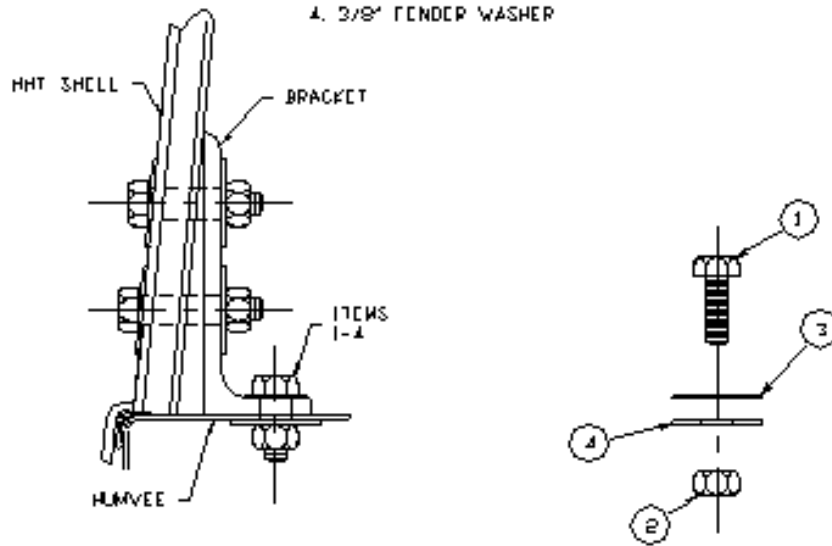

FIG 1-5

14. Close the vehicle tailgate. Place a strip of masking tape, approximately 20" long, on the top of the vehicle tailgate, centered. Close the hard top doors. Close the latches repeatedly until the strike position of the latch rods is visible on the masking tape. Drill 2 clearance holes in the top of the tailgate with a 7/16" drill bit for the latch rods. Remove the tape from the vehicle tailgate. See figure 1-6.

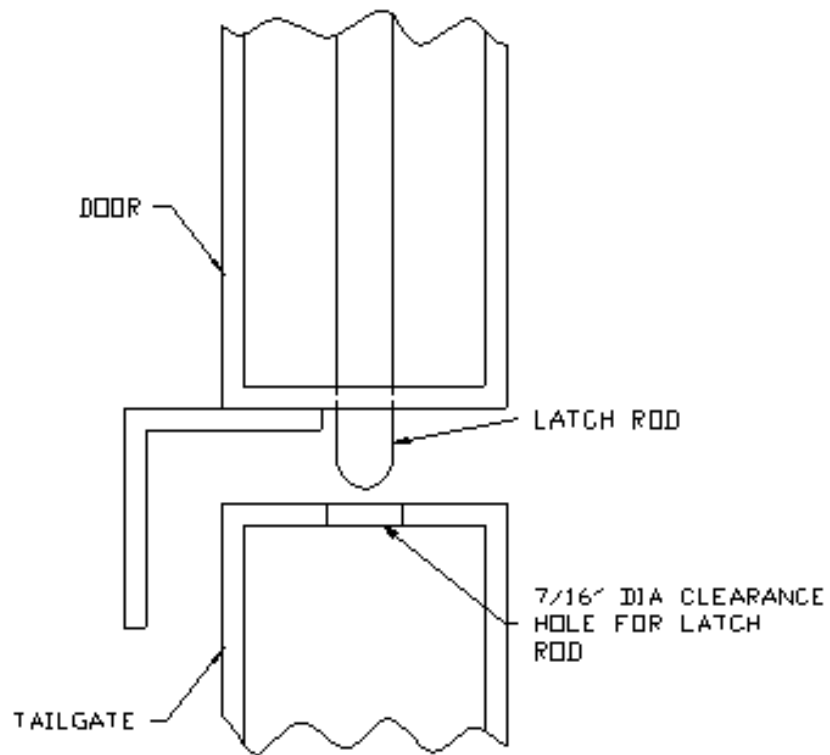

FIG.
1-6

15. Readjust the vehicle doors if needed.

16. From the inside of the vehicle apply a bead of silicon between the windshield frame and top gasket.